



CONQUEROR KIOSK

DELIVER AMAZING SERVICE





CONQUEROR KIOSK



Easy Check-In with Conqueror Web

The Ultimate Consumer Journey

The Conqueror Kiosk is part of the Experience Relationship Manager (XRM) growing suite of marketing technology and tools that empower you to create the Ultimate Consumer Journey through your business.

As part of the Ecosystem, the Conqueror Kiosk works together with your existing Conqueror X management system and POS, as well as the Conqueror Web booking system. This allows your guests to have an easy and seamless experience whether they start on the web or walk in through your front door. For you, setup is turnkey, and your look, feel and branding are consistent through every interaction.

Convenient Self-Service

The Conqueror Kiosk is built with the consumer in mind – and delivering the convenient and easy interaction they seek. Consumer expectations of service, convenience and technology are extremely high, arguably higher than ever before. They also expect to be in control of their experience. The Conqueror Kiosk is the perfect way to provide service the way they want – helping them find the right programs and entertainment for them and conducting transactions that are a breeze.

Always Upselling

The Conqueror Kiosk is the perfect way to showcase your offerings and the only system built to upsell your customers to play and spend more while reducing lines and wait times. It literally never tires of upselling – always promoting your bowling programs and packages, food and beverage, activities, and more. All of which helps drive higher spend. When your guests are enticed by the extras that they want at the right time, they will buy them.

Greater Staff Flexibility

In a time when finding staff and managing overhead is difficult, the Conqueror Kiosk is a great way to improve service and better deploy your staff. The Conqueror Kiosk speeds up lines, conducts complete transactions, moves guests through the arrival and purchase process, always shows up on time, never calls in sick, and always tries to upsell with special offers and additional items. One staff member can easily manage and oversee multiple kiosks, and the kiosk can advise the staff when extra help is needed by a guest.

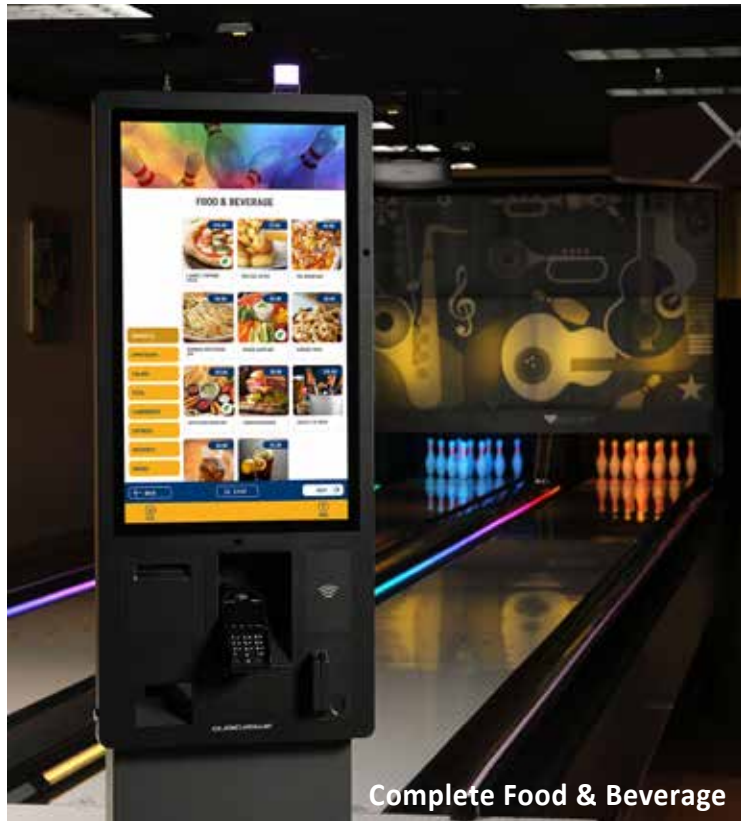

Complete Food & Beverage

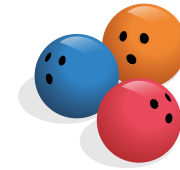

Walk In and Play Now

Make Conqueror Kiosk the first touchpoint for your guests when they arrive. Through the “Play Now” service they can explore programs and select their perfect bowling offer, customize their experience with food & beverage and extras, enter their names and preferences, and complete their payment. Everything can be completely automated, including lane assignment and opening, and instructions for their next steps – like stopping by the desk to pick up shoes. If their choice isn’t available just yet, guests can pick the next open time slot and be notified by text as soon as their lane is ready.



Easy Check-In with Conqueror Web

Consumers are looking for fewer touch points and easier ways to interact with your business. For those who start their journey on your website and book through Conqueror Web, it could not be faster or easier. They simply scan their confirmation QR code at the Conqueror Kiosk, review their selections, are encouraged to buy extras, and complete any payments – then the system does the rest. If the lane is ready, they can be sent straight away. Or if there is a bit of a wait, they will be advised by text message when the lane is available.



Complete Food & Beverage

With the dedicated Food & Beverage Conqueror Kiosk service, you can shrink lines, showcase options, take payment, and generally improve the entire process for your guests. Guests are presented with a beautiful graphical menu complete with always up-to-date dynamic pricing, specials, and availability of items. Modifiers ensure that they can make their order just right. Complete payment flows and multiple custom options for delivery location (to the lane, to the table, pickup, etc.) allow for a complete hands-off experience for your guests.



Walk-In and Play Now



CONQUEROR KIOSK

Flexible Configurations

No two bowling or entertainment centers are exactly alike. The Conqueror Kiosk comes in three different physical configurations to support different size operations and center layouts so you can deliver service to your guests at just the right place. You only need power and ethernet to connect to your Conqueror network and the Conqueror Cloud.

SINGLE-SIDED FLOOR STANDING

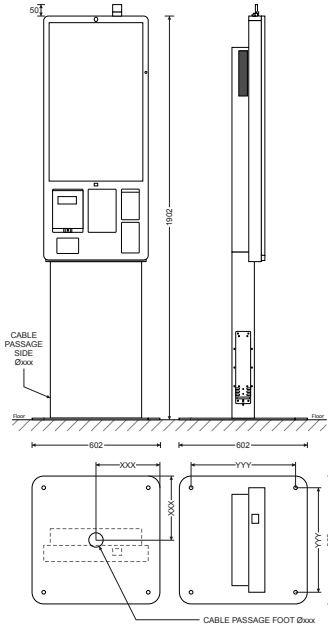

Dimensions (W x D x H)	602 x 602 x 1902 mm
	23.7 x 23.7 x 74.9 inches
Weight	65 Kg
	143.3 lbs.

DUAL-SIDED FLOOR STANDING

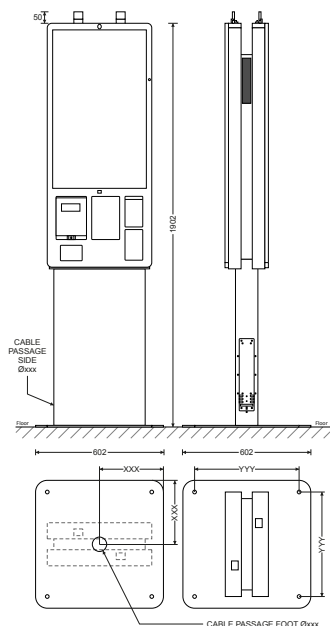

Dimensions (W x D x H)	602 x 602 x 1902 mm
	23.7 x 23.7 x 74.9 inches
Weight	81,5 Kg
	179.7 lbs.

WALL MOUNTED

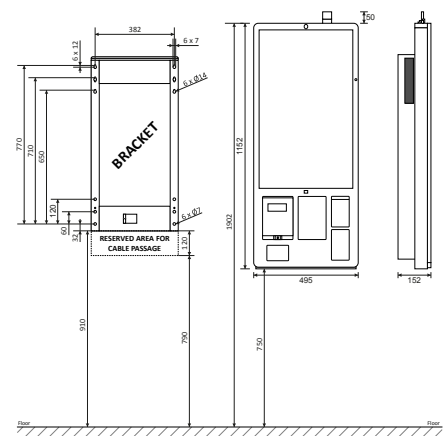

IMPORTANT: always fix the pedestal to the floor

Unless otherwise specified dimensions are in millimeters.

Dimensions (W x D x H)	495 x 152 x 1152 mm
	19.5 x 6 x 45.4 inches
Weight	35 Kg
	77.2 lbs.



CONQUEROR X



CONQUEROR XRM



To learn more, visit our website:
www.qubicaamf.com/conquerorkiosk

Conqueror Kiosk requires Conqueror X Business Preferred and active Conqueror Maximization Program

QUBICAAMF

WORLDWIDE HEADQUARTERS
8100 AMF Drive - Mechanicsville, VA 23111 - USA - Tel. +1 (804) 569-1000 - Fax: +1 (804) 559-8650
Toll free 1-866-460-QAMF (7263)

EUROPEAN HEADQUARTERS
Via della Croce Coperta, 15 - 40128 Bologna - Italy - Tel.+39 (051) 4192-611 - Fax +39 (051) 4192-602

www.qubicaamf.com - info@qubicaamf.com